

Concrete Water Tanks - Standard

Concrete Tank with 80 mm standard lid & Integrated Self Anchoring Collar (I.S.A.C.)

	ORDER CODE	CAPACITY	WIDTH	HEIGHT	I.S.A.C. WIDTH	HOLE DEPTH
	CWT4	4,000 LITRES	2730 mm	1150 mm	100 mm	1150 mm
	CWT6	6,000 LITRES	2830 mm	1580 mm	150 mm	1580 mm
	CWT10	10,000 LITRES	2830 mm	2470 mm	150 mm	2470 mm

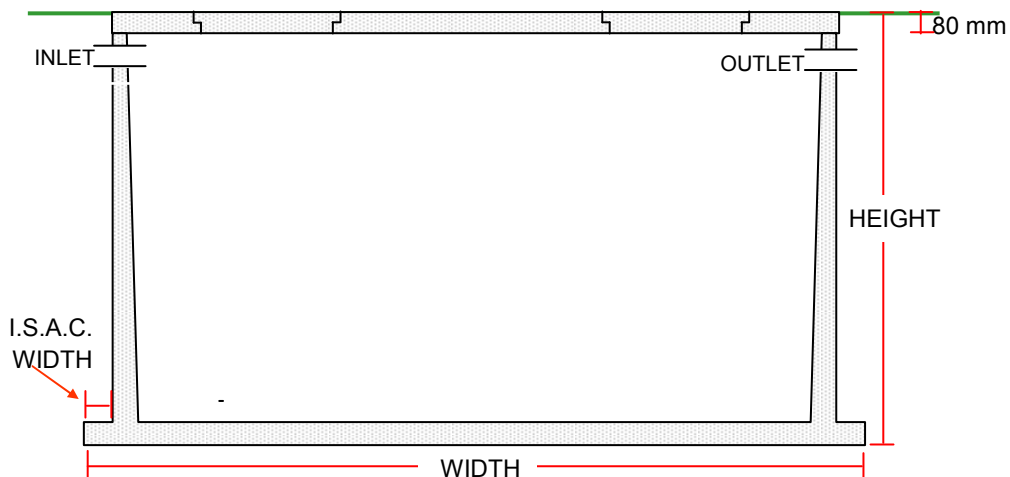

HOLE EXCAVATION

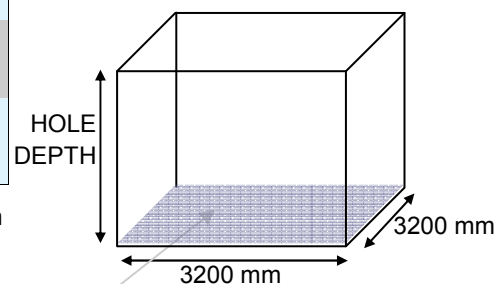

Level base with 50mm minimum sand or metal dust

Concrete Tank with 150 mm heavy duty lid, 350 mm turret, flow through filter & Integrated Self Anchoring Collar (I.S.A.C.)

	ORDER CODE	CAPACITY	WIDTH	HEIGHT	I.S.A.C. WIDTH	HOLE DEPTH
	CWTHD4	4,000 LITRES	2730 mm	1570 mm	100 mm	1570 mm
	CWTHD6	6,000 LITRES	2830 mm	2000 mm	150 mm	2000 mm
	CWTHD10	10,000 LITRES	2830 mm	2890 mm	150 mm	2890 mm

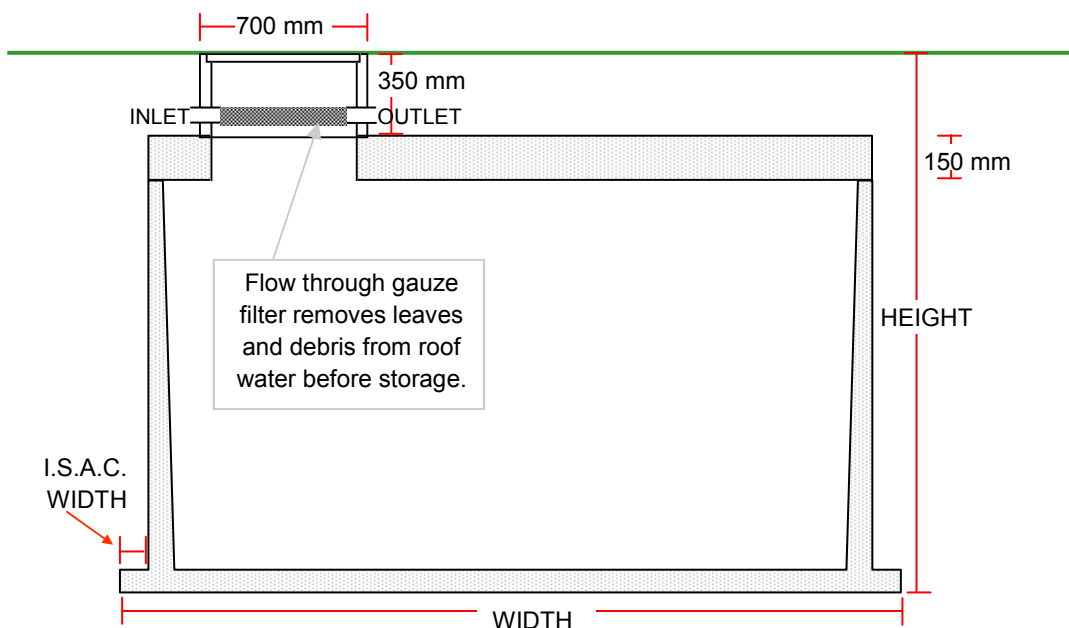

HOLE EXCAVATION

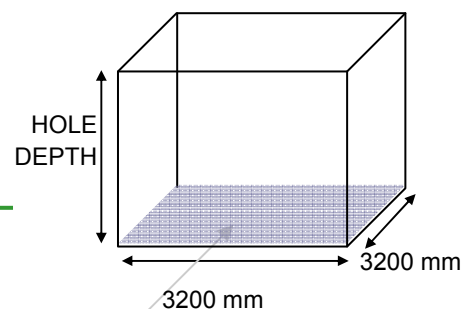

Level base with 50 mm minimum sand or metal dust

Concrete Water Tanks - Installation Manuals

1. Excavation of hole to drawing specifications. Lid depth 80mm or 150mm.
2. Installation to comply with local Council requirements.
3. **Install tank in hole with level bottom using 50mm minimum level sand or metal dust aggregate base. Warranty void if not installed according to installation manual.**
4. Connect pipe work to tank.
5. Tanks have a 100mm DWV pipe protruding 50mm from tank or turret to allow 100mm connection from dwelling.
6. Tank includes an integrated self anchoring collar.
7. Backfill tank.
8. It is the plumber's or owner's responsibility to provide all weather access for delivery truck to the excavated hole. **Ensure access is free of power lines and overhanging trees.**
9. Location of tank - avoid storm water run off areas.
10. When backfilling tank ensure no large rocks in excess of 200mm enter hole. Any damage to tanks, e.g. large rocks or machinery damage, during backfilling, is the responsibility of the contractor and/or owner and is not covered by warranty.
11. Standard lids are designed for pedestrian traffic only and must not be covered by any fill materials.
12. Heavy duty lids are suitable for covering with material to the top of manhole centre riser.
13. Tank lids & manhole risers are sealed at factory using an approved sealant.
14. Additional concrete around tank is recommended for the 10,000 litre tank with 80mm lid.

Cylindrical vertical axis collection well.

Manufactured by casting & vibrating steel reinforced concrete.

LID

- 150mm thick double reinforced with F82 mesh using 40mpa concrete for below ground application up to 4 tonnes load limit

- 80mm thick lid for in-ground, pedestrian traffic only.

RISER—concrete access covers for non-trafficable areas, i.e. lawn or garden.

- Class B steel access covers for all areas including driveways, up to 2.5 tonnes load limit.
- Class D heavy duty steel access covers up to 4 tonnes load limit on tank.

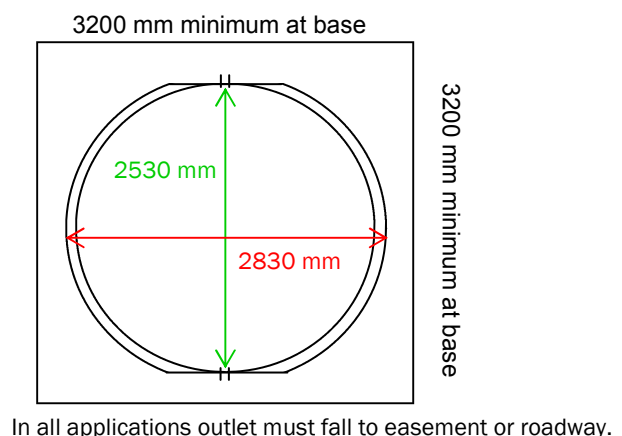

Concrete Water Tanks - Options

Suction line with float

	ORDER CODE	
	PFL	25mm suction line with float (see right)

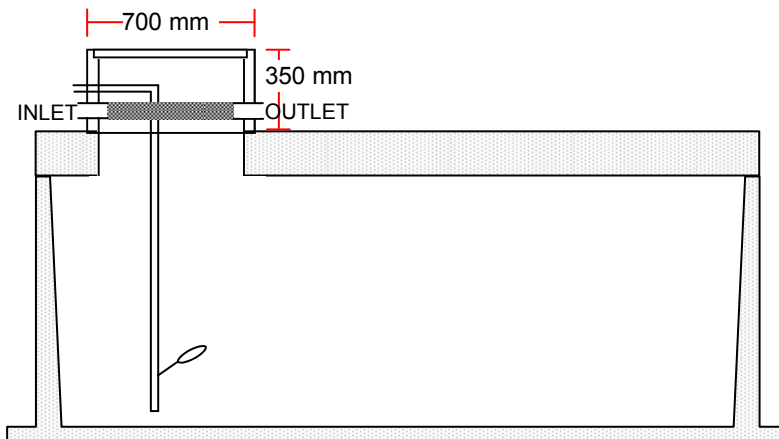

Havestock Steel Access Covers.

Used in conjunction with 150 mm heavy duty lid

	ORDER CODE	CLASS
	SACB	CLASS B - for all areas including driveways, load limit 2.5 tonnes
	SACD	CLASS D - heavy duty, load limit 4 tonnes on tank

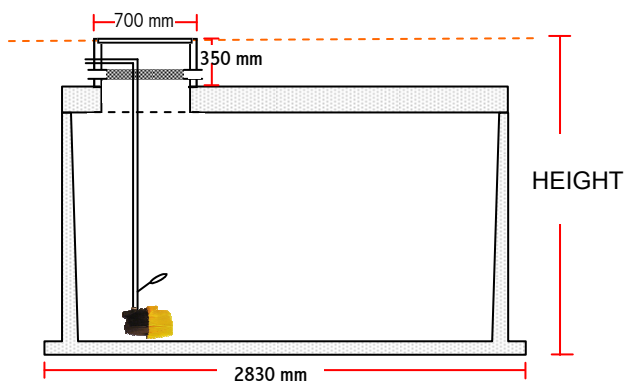
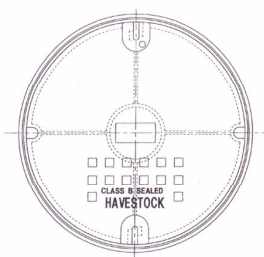

Example of single tank with 150mm heavy duty lid, 350mm turret, flow through filter and **submersible pump installed.**